

# BACKHOE LOADERS

B100 C | B110 C | B115 C







## Right for your needs.

Many business operations will have a need for a loader that offers the versatility to do a lot more than just move bulk material. Typical alternative applications will include grading and levelling, the ability to grab heavy items such as trunks and concrete pillars plus a tractor unit with the traction and power to push materials or items into place or out of the way.

With a 4 in 1 bucket, a backhoe loader will deliver this exceptional performance with just the one attachment. Choose a 6in1 bucket and you have the option to flip down adjustable pallet forks, ideal for handling palletised loads without the need for a dedicated vehicle.

The backhoe can be equipped with a wide choice of buckets to match excavation, water course clearance, trenching and other demands. Post hole borers, hydraulic hammers and countless other tools can all be fitted. The long reach of both the standard and telescopic dipper, up to a massive 6965mm, allows long reach and digging depth comparable to many conventional dedicated excavators. Add to this the new revised cab featuring a new heated seat and up to ten LED lights and exterior side lights on the cab roof, there are no performance compromises with a New Holland backhoe loader.



Models	Engine power (hp)	Loader lift capacity Straight/Tool Carrier (kg)	Max. backhoe reach (mm)	Hydraulic flow (l/min)
B100 C	98	3550/3450	6965	151/165
B110 C	111	3550/3450	6965	151/165
B115 C	111	3380	6965	165

## In-built versatility.

New Holland backhoe loaders are your versatile choice for loading, grading, grabbing, lifting, excavating, digging, planting, post hole boring and, well the list goes on. Businesses from agriculture through to horticulture, landscaping through to drainage and irrigation need versatile and cost effective equipment. With a backhoe loader there are loader and backhoe specification choices. The all-wheel steer B115 C boasts powerful performance in challenging conditions with no compromise on agility. Entry level B100 C models are affordable but come with a high standard specification to suit a wide range of needs. Available through selected New Holland Agriculture dealers, the latest C series backhoe loader is one investment that will never be short of work.





# Welcome aboard.

A good cab will offer good operator comfort, excellent ergonomics and plenty of room to speed switching between loader and backhoe operation. A great cab will combine this with excellent all-round visibility, first class heating and ventilation with low noise and vibration levels.

With the newly refreshed cab on New Holland backhoe loaders, you get all the small additional details that make the cab extra special. Room for tools and oddments as well as personal items. A high grip floor covering to help prevent the operator slipping when entering with muddy footwear. A powerful lighting package featuring up to ten optional LED lights giving true 360 degree light pattern thanks to the roof mounted side lights. Large retractable sunshades, cup holders, glove box and a deluxe pneumatic heated seat. To top it off, the engine exhaust pipe has been relocated to the right side of the cab to provide a clear view of the loader arm.



- Improved in-cab storage



- Spacious cab allows easy seat transition to operate the backhoe
- A choice of entry level mechanical and deluxe heated pneumatic suspension seats are available
- Low 77dB(A) in-cab noise level
- Good visibility is a key design priority, C series backhoe loaders benefitting from extremely slim cab pillars, front and rear



- A pillar exhaust mount for clear view of loader



- Key controls mounted on side to allow operation from both forward and backhoe seat positions
- Uncluttered side console housing all necessary buttons
- The dashboard is easy to read with the seat in either its forward or reverse position



- Single multifunction proportional control lever for all loader controls
- 4 in 1 or 6 in 1 bucket opening, diff lock and transmission de-clutch functions are also activated from the lever



- Powerful heating and ventilation with standard air conditioning ensures operator comfort throughout the day



- Up to ten LED work lights including roof mounted side lights are available



- Backhoe joystick towers adjust in all directions for the most comfortable position



- Up and over rear window, light and easy to open and close

# PowerShift™ or Powershuttle, you decide.

New Holland offers its backhoe loaders with switchable two or four wheel drive, a Powershuttle forward / reverse mechanical transmission or automatic PowerShift™ transmission. The all-wheel steer B115 C has equal size front and rear wheels with selectable front, all-wheel and crab steer modes.



## The right front axle for the job

- The heavy duty front axle on B100 C and B110 C models has an open differential
- A tight turn radius can be maintained in all conditions



## The right rear axle for the job

- The rear axle on all two-wheel steer models is fitted with a fully locking rear differential, engaged via a button on the loader joystick







### Mechanical four-speed Powershuttle

- Floor mounted gear lever with steering column mounted electro-hydraulic forward / reverse shuttle
- Four gears with transmission de-clutch button incorporated in the gear lever
- Affordable, dependable and easy to use
- Ideal choice where the backhoe will see more use than front loader



### Automatic four-speed PowerShift™

- Steering column mounted lever for shuttle and speed selection
- Fully modulated gear shifting with speed matched forward and reverse
- Ease of use matched to low maintenance demand
- Ideal transmission choice for extensive front loader duties
- Loader joystick fitted with transmission de-clutch button to divert full power to hydraulics as required
- Selectable two or four-wheel drive

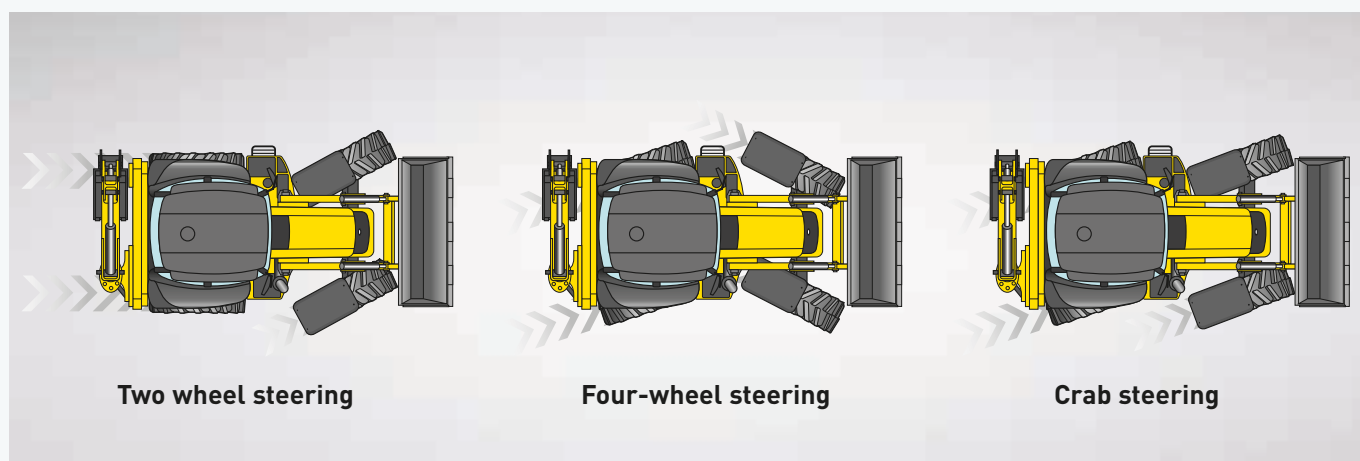

### Four-wheel steer B115 C

New Holland B115 C models can be operated in one of three steering modes:

- Conventional front-wheel steering is ideal for normal loading and transport applications
- All-wheel steer delivers excellent manoeuvrability with no impact upon stability
- Crab steer is ideal for working up close to a trench or obstacle and can be useful when working over sensitive terrain to reduce trafficking
- The all-wheel steer B115 C delivers excellent traction with limited slip differentials in both the front and rear axles. Power is automatically diverted to all wheels in adverse conditions with no need for any operator input
- Self-adjusting, the oil immersed disc brakes are designed to offer dependable performance. Mounted within the reduction hubs, the brakes can be easily serviced with no need to strip the axle

# The figures tell you everything.

With a New Holland backhoe loader, there is no compromise in performance. Dependent upon model, the front loader can be fitted with a front bucket of either 0.9m<sup>3</sup>, 1.0m<sup>3</sup> or 1.15m<sup>3</sup> capacity and raise loads of 3380kg - 3550kg to heights of up to 3520mm.

The backhoe has a digging depth down to 4665mm increasing up to 5880mm with the telescopic dipper. The bucket breakout force is as high as 5970daN, the dipper breakout coming in at 3225daN or 2390daN if extended. With a New Holland backhoe loader there is absolutely no compromise in performance.

Models		B100C B110C TC		B115C TC	
Loader specifications		Tool Carrier		Tool Carrier	
Lift capacity	(kg)	3450		3380	
Hinge pin height	(mm)	3460		3520	
Models		B100C		B100C - B110C - B115C	
Backhoe specifications		Short	Extended	Long	Extended
Digging depth	(mm)	4385	5625	4665	5880
Max. bucket breakout force	(daN)	5970	5970	5970	5970
Max. reach	(mm)	5580	6315	5830	6965



## Front loader - TC Tool Carrier loader designs

TC Tool Carrier loader arm features:

- Mechanical parallel lift and lower
- Greater reach than straight arm
- Ideal for pallet and loading duties



## Common standard loader features

- Auto-glide loader suspension
  - automatically activates / deactivates at speeds above / below 9.2kph / 7.6kph
  - improves material retention over uneven terrain
  - enables faster load cycle times
  - higher travel speeds for reduced journey times
- Return to dig and float modes
- Choice of standard, 4 in 1 or 6 in 1 buckets
- All buckets have bolt-on teeth for easy renewal



## Versatile bucket options

- Versatile 4 in 1 bucket is suitable for work to include dozing and grading, bulk materials handling and work as a grab
- The 6 in 1 design adds adjustable forks for pallet work, lifting open loads and working with a strop



## Backhoe

Standard features include:

- Curved arm design for easier loading over trailer sides and obstacles
- Long life pivots with ground level greasing points
- Wide pad stabilisers with adjustable footing
- Powerful bucket and dipper breakout for optimum performance

Key backhoe specification choices include:

- Fixed or extendable dipper arm option
  - fixed dipper offers 4710mm dig depth
  - telescopic dipper extends dig depth to 5785mm
- Fixed centre or hydraulic side shift option
- Direct fit or quick coupler bucket choice
- Object Handling kit available. EU certified to allow handling of suspended items



- Conventional pilot controls for the backhoe provide good feedback and response from the hydraulics



- With full proportional control, pilot backhoe control joysticks are fully adjustable
- Selectable ISO or SAE operating patterns



- Object Handling kit adds lifting hook, safety valves to both boom and dipper and overload protection



- Hydraulic side shift allows precise backhoe positioning and enables the operator to optimise bucket visibility when excavating a trench or working alongside an obstacle

# Hydraulics to meet every demand.

To exactly match end user needs, New Holland backhoe loaders are offered with a choice of hydraulic pump designs. In addition, an auxiliary hydraulic circuit is available to power attachments to include hydraulic breakers and soil augers.

Two hydraulic pump designs are offered:

## Twin gear pump

- Simple
- Constant flow
- Fast warm up
- Straightforward service and maintenance
- For general use. Suits applications with limited roading
- Maximum flow 151l/min @ 2200rpm
- Maximum operating pressure 205bar

## Variable displacement pump

- Only active when there is a demand for oil
- Flow rate proportional to demand
- Reduces fuel consumption
- Reduced oil temperature due to flow on demand
- Ideal for intensive backhoe operation and frequent roading
- Variable flow from 6 to 165l/min
- Maximum operating pressure 205bar

- A variable displacement hydraulic pump only delivers flow on demand, saving fuel when roading and in applications such as dozing and grading





- An optional auxiliary hydraulic circuit delivers 0-135l/min
- Ideally suited to working soil augers, large grabs and hydraulic breakers



# Powerful economy.

Developing 98, 111hp dependent upon model, the FPT Industrial F5H 3.4 litre four-cylinder engine in backhoe loaders is the same unit proven in New Holland T5 tractors. Compliant with stringent Tier 4B emission regulations, the engines have an advanced throttle control system. This allows the operator to adjust how the engine responds to throttle inputs from smooth to fast.

## Powered by FPT Industrial

New Holland are not going it alone when it comes to Tier 4 technology, they can draw on the experience of their in-house engine development specialist: FPT Industrial.

**Pioneers:** Common Rail technology developed by FPT Industrial at their R&D excellence center in Arbon, Switzerland in the 1980s and brought it to the masses in 1997 on the Alfa Romeo 156. They were the very first to introduce it on agricultural machines on the TS-A tractor. Pioneering. Always.

**Cleaner:** For the eighth consecutive year, CNH Industrial has topped the Dow Jones Sustainability World and Europe Indexes for the Industrial Engineering sector. Cleaner. Everywhere.

**Proven:** FPT Industrial has pioneered SCR technology since 1995 and has already produced over 1 million SCR engines during the last eight years for the agricultural, construction and haulage industries. Reliability. Confirmed.

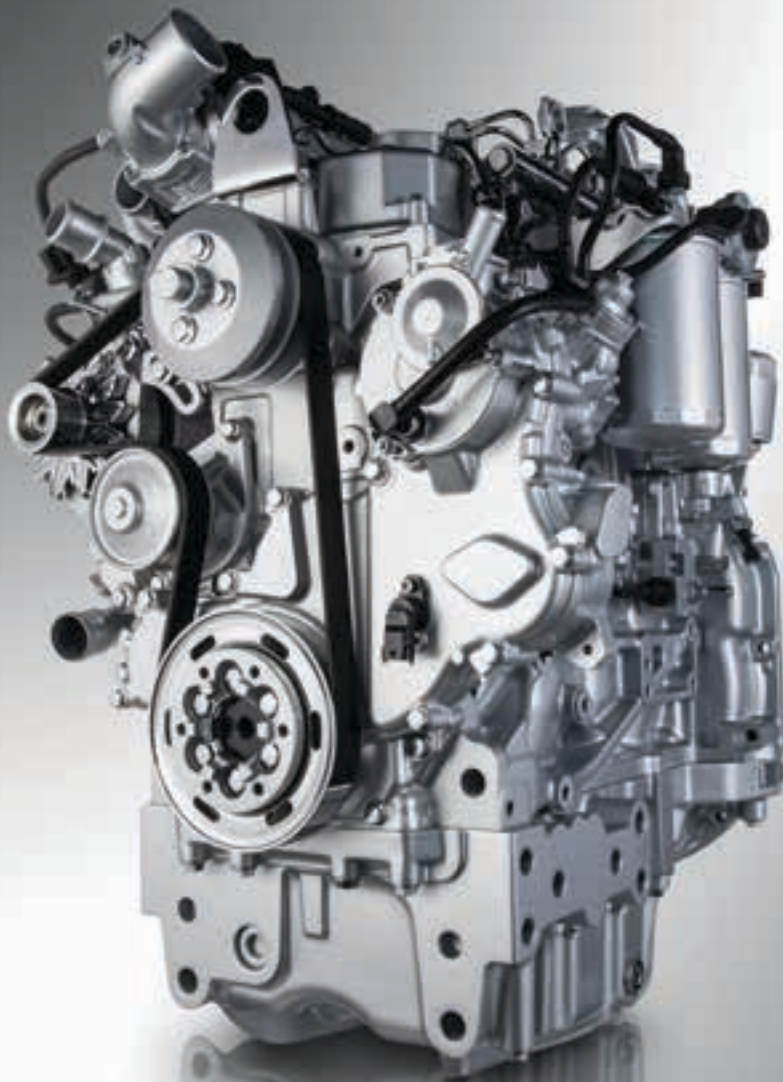

### Compact HI-eSCR after-treatment emission system

New Holland sister company FPT Industrial developed the F5H engine to meet tough emission regulations without the need for a Diesel Particulate Filter. By combining proven Selective Catalytic Conversion with exhaust gas recirculation, an F5H engine can be operated at low loads for an extended period without needing to regenerate a blocking a DPF filter.

- Output choice of 98 and 111hp
- New side mounted for exhaust stack for improved visibility
- Engine shut-down protection in the event of low oil pressure plus high coolant or transmission oil temperatures
- 132 litres fuel and 42 litre AdBlue capacity
- Three throttle settings, soft, normal and fast are offered. The operator can select the throttle setting best suited to the application

### More time working

- 600hr\* engine service intervals

\* when AMBRA UNITEK engine oil is used only

### Chassis

All backhoe models benefit from a full frame chassis, its exceptional strength diverting all stress through the robust frame with no load on the engine or transmission.

- Robot welded full length frame chassis
- No stress on engine or transmission
- Plate reinforced stress points
- Cast backhoe slider interface
- Open design to facilitate maintenance

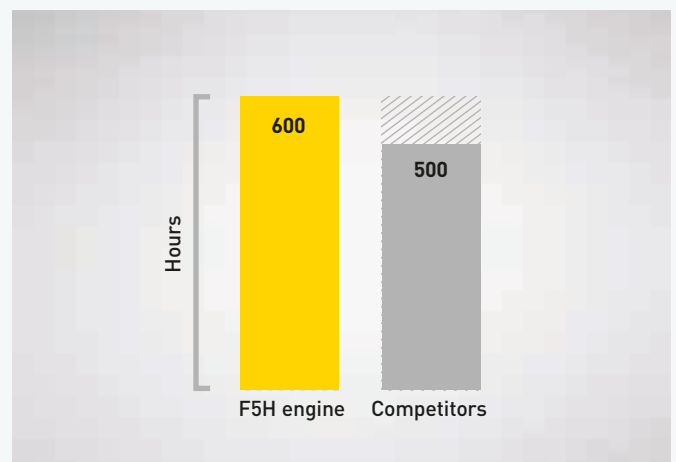

## Spend time saving money.

A key to equipment performance and longevity is routine care. New Holland has designed the backhoe loader so it takes the minimum of time to carry out routine checks. Service intervals are also fixed at 600 and 1000 hours, with easy access to all key fuel, engine, transmission and hydraulic filters. Extensive New Holland dealer network for full support is always handy.

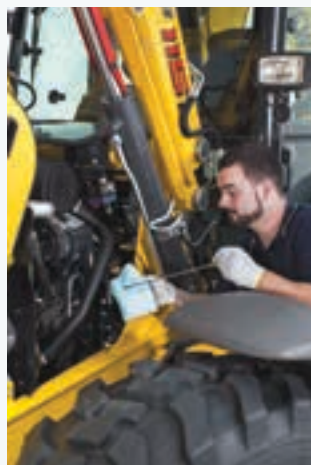
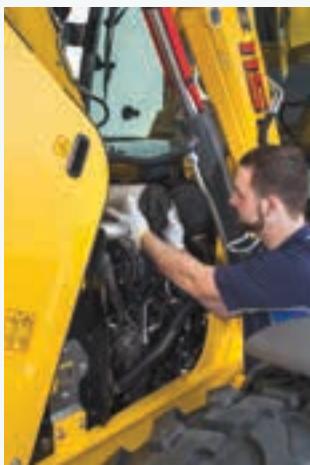

- One piece hood for full engine access
- All key daily checks grouped together

- Battery disconnect and remote jump start terminals easily accessible



- All key lubrication points on the loader and backhoe have ground level access
- Making key service items accessible from ground level makes the job simpler, faster and safer
- Maintenance free disc brakes are standard



# New Holland Services.



## Finance tailored to your business

CNH Industrial Capital, the financial services company of New Holland, is well established and respected within the agricultural sector. Advice and finance packages tailored to your specific needs are available. With CNH Industrial Capital, you have the peace of mind that comes from dealing with a financing company that specialises in agriculture.



## Trained to give you the best support

Your dedicated New Holland dealer technicians receive regular training updates. These are carried out both through on-line courses as well as intensive classroom sessions. This advanced approach ensures your dealer will always have the skills needed to look after the latest and most advanced New Holland products.



## New Holland App

Product apps - NH Weather - PLM Calculator - PLM Academy

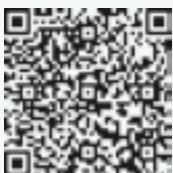

## New Holland Style

Want to make New Holland a part of your everyday life? Browse the comprehensive selection on [www.newhollandstyle.com](http://www.newhollandstyle.com). A whole range of items are available including hard wearing work clothing and a vast selection of scale models, together with so much more. New Holland. As individual as you.

Models	B100 C	B110 C	B115 C
<b>New Holland Engine*</b>	FPT Industrial F5H	FPT Industrial F5H	FPT Industrial F5H
No. of cylinders /valves	4 / 4	4 / 4	4 / 4
Capacity (cm <sup>3</sup> )	3400	3400	3400
Aspiration	Turbocharged	Turbocharged	Turbocharged
Injection	Common rail	Common rail	Common rail
ECOBBlue™ Compact HI-eSCR system (selective catalytic reduction)	●	●	●
Compliant with engine emissions regulations	Tier 4B / Stage 4	Tier 4B / Stage 4	Tier 4B / Stage 4
Rated engine power ISO TR14396 - ECE R120 [kW/hp(CV)]	72/98	82/111	82/111
Rated engine speed (rpm)	2200	2200	2200
Maximum engine power ISO TR14396 - ECE R120 [kW/hp(CV)]	84/114	89/121	89/121
Maximum torque ISO TR14396 @ 1400rpm (Nm)	453	460	460
Fuel tank capacity (l)	131	131	131
<b>Electrical</b>			
12 Volt alternator (Amps)	160	160	160
Battery capacity (CCA / Ah)	900 / 95	900 / 95	900 / 95
<b>Transmission</b>			
<b>Powershuttle transmission (40kph)</b>	●	●	-
Type (FxR)	4x4 mechanical	4x4 mechanical	-
Forward / Reverse maximum speed (kph)	39 / 46	39 / 46	-
<b>PowerShift™ transmission (40kph)</b>	○	○	●
Type (FxR)	4x3 electronic	4x3 electronic	4x3 electronic
Forward / Reverse maximum speed (kph)	40 / 26	40 / 26	42 / 29
<b>Axles</b>			
Front axle type	Open diff	Open diff	Open / Limited slip diff
Front axle oscillation (°)	+/- 11	+/- 11	+/- 11
Rear axle (mm)	100% lockable	100% lockable	Open / Limited slip diff
<b>Turning radius - 2 wheel steer mode, 4WD engaged, without brakes</b>			
External tire (mm)	4300	4300	7830
Bucket edge (mm)	5600	5600	8550
<b>Hydraulic system</b>			
Pump type standard	Twin gear	Twin gear	Variable displacement
Pump type optional	Variable displacement	Variable displacement	-
Twin gear pump flow @ 2200rpm (l/min)		151	
Variable displacement pump flow @ 2200rpm (l/min)		165	
Maximum pressure level (bars)	205	205	205
<b>Brakes</b>			
Type	Power brakes	Power brakes	Power brakes
Brake disc, quantity x area (cm <sup>2</sup> )	4 x 309	4 x 309	6 x 182
<b>Cab</b>			
Cab with FOPS - Level 2	●	●	●
Work light package: 10 halogen / 10 LED	● / ○	● / ○	● / ○
Mechanical Comfort seat	●	●	●
Pneumatic suspension Deluxe seat	○	○	○
Air conditioning	○	○	○
Noise level - internal / external [dB(A)]	77 / 102	77 / 103	77 / 103
Vibration levels - upper limbs / abdomen (m/s <sup>2</sup> )	2.5 / 0.5	2.5 / 0.5	2.5 / 0.5
<b>Tyres</b>			
Front tyre diameter (inches)	18 or 20	18 or 20	28
Rear tyre diameter (inches)	26 or 28	26 or 28	28
<b>Operating weight</b>			
With standard backhoe and 6-in-1 bucket (kg)	8120	8120	8370
With extendible backhoe and 6-in-1 bucket (kg)	8800	8800	9100

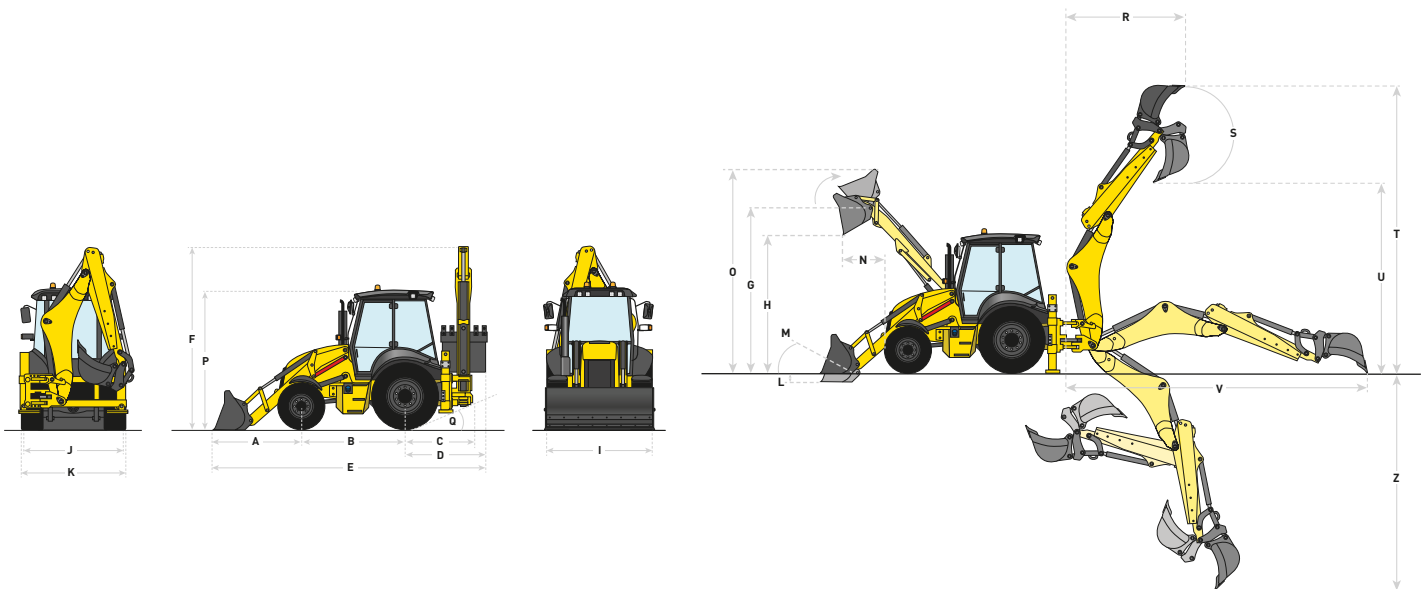

## Dimensions

		B100C - B110C	B100C - B110C TC	B115C TC
<b>A</b> - Ground distance over front axle	(mm)	1870	1975	1975
<b>B</b> - Wheelbase	(mm)	2175	2175	2200
<b>C</b> - Pivot distance over rear axle	(mm)	1325	1325	1340
<b>D</b> - Max. distance over rear axle (with 915 mm backhoe bucket)	(mm)	1780	1780	1795
<b>E</b> - Overall length	(mm)	5825	5930	5970
<b>F</b> - Height to top of boom	(mm)	3875	3875	3930
<b>Q</b> - Back ramp angle	(°)	23	23	22
<b>P</b> - Cab height	(mm)	2950	2950	3000
<b>I</b> - Loader bucket width	(mm)	2250	2250 / 2400	2400
<b>J</b> - Stabilizer width on ground	(mm)	2300	2300	2275
<b>K</b> - Width at tires	(mm)	2325	2325	2390

## Loader specifications

		B100C - B110C TC	B115C TC
<b>Design</b>		<b>Tool Carrier</b>	<b>Tool Carrier</b>
Bucket size - general purpose type	(m <sup>3</sup> )	1.0	1.15
Maximum loader breakout force	(daN)	6545	5410
Lifting capacity to maximum height	(kg)	3450	3380
<b>L</b> - Digging depth	(mm)	120	90
<b>M</b> - Bucket roll back angle on ground	(°)	43	45
<b>N</b> - Reach at full height	(mm)	830	750
<b>O</b> - Maximum operating height	(mm)	4250	4310
<b>G</b> - Hinge pin height	(mm)	3460	3520
<b>H</b> - Maximum dump height under bucket at 45°	(mm)	2750	2745

## Backhoe specifications

		B100C		B100C - B110C - B115C	
<b>Arm type</b>		<b>Short</b>	<b>Short Extended</b>	<b>Long</b>	<b>Long Extended</b>
Bucket Breakout force	(daN)	5970			
Arm digging force	(daN)	3765	2595	3225	2390
<b>R</b> - Digging reach at max. height	(mm)	2265	3240	2490	3485
<b>S</b> - Bucket rotation	(°)	203			
<b>T</b> - Digging height	(mm)	5425	6175	5615	6350
<b>U</b> - Dumping height	(mm)	3570	4325	3765	4500
<b>V</b> - Digging reach at ground level	(mm)	5580	6315	5830	6965
<b>Z</b> - Digging depth	(mm)	4385	5625	4665	5880

# New Holland Top Service: customer support and customer information.

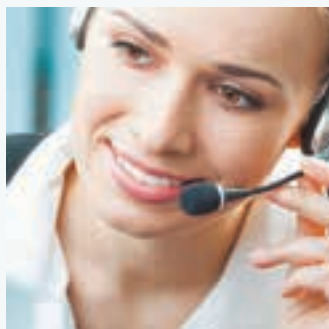

## Top Availability

If you need information, or have an out of hours question, ring our toll-free number\*. All day, every day, we are just a call away.



## Top Speed

Express parts delivery: when you need it, where you need it!



## Top Priority

Fast-track solution during the season: because your harvest can't wait!



## Top Satisfaction

We drive and track the solution you need, keeping you informed: until you are 100% satisfied!



### For more details, ask your New Holland dealer!

\* Calls to the Top Service team are free from landlines in the United Kingdom and Republic of Ireland. UK-based mobile calls are also free, but Republic of Ireland mobile users should call 01 2421881 and this will be charged at your standard network rate.

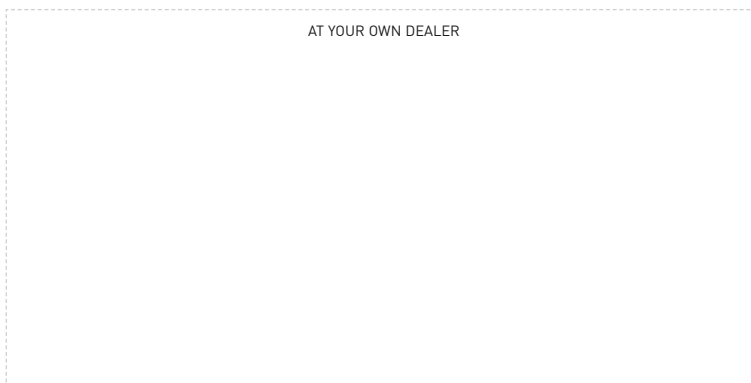

[www.newholland.com/uk](http://www.newholland.com/uk) - [www.newholland.com/ie](http://www.newholland.com/ie)

