



Broughan

ENGINEERING LTD.COM

Ireland's Premier Trailer Manufacturer

Where Quality Comes First





Broughan

ENGINEERING LTD.COM



Broughan Engineering Ltd designs, engineers and manufactures a full range of high quality, bespoke agricultural trailers, located just outside Tullow in County Carlow and owned by brothers and founding directors Patrick and Paul Broughan.



Broughan Engineering Ltd was established 15 years ago, building upon an engineering legacy started by their father Paddy Broughan some 40 years ago. Broughan Engineering manufactures a wide range of high quality trailers, which includes grain/silage, cattle, bale, low loaders and dumpers. Today's consumer requirements vary greatly, often requiring a bespoke design approach to suit each buyer, which is a highly valued attribute of the business. The company motto "where quality comes first" shines through the superior workmanship in every aspect of the finished product.



Grain, Silage & Root Crop Trailers



“Our Broughan Trailers are going on their third year now and we couldn’t be happier with them. They follow well, even without steering axles, so stable on the road, really stable in the field and really easy to pull full loads with little tractors. They’re strong and well built, tyres don’t damage the field, paint is of high quality as are the LED lights. Whatever colour scheme you ask for you get and the spec you can have is endless. I’ve shown off my trailers for contractors up and down England and they’ve always complimented them. These trailers are built to last”

- George Blything, customer of Cheshire Farm Machinery



Our Products



Silage, Grain & Root Crop Trailers



Cattle Trailers



Bale & Flat Trailers



Dump Trailers



Low Loaders



Bespoke Trailers





Grain, Silage & Root Crop Trailers

Our Grain, Silage and Root Crop Trailers range from 12 ton to 24 ton capacity. With our high spec and custom tailored design, we provide a market leading trailer to suit our customer's needs.



Optional Roll over cover with option of colours



Optional Ladder & Catwalk



Optional Grain Chute



Rear Crash Bar & LED Lights



Optional Rear Hitch



Grain, Silage & Root Crop Trailers



Grain Trailers come standard with 10 Stud Commercial Axles, Sprung Drawbar, 3mm Sides, 5mm Floor and much more, with a large range of optional extras available.



Hydraulic Auto-Lock Rear Door



Trailers come standard with hydraulic brakes with the option of adding air or ABS brakes

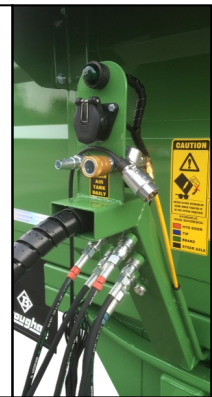

Optional Tool Box



Optional Spoon Hitch



Optional Swivel Hitch





Grain, Silage & Root Crop Trailers

The Broughan Grain, Silage and Root Crop trailer can be manufactured with a long list of optional extras. Whatever the requirement, you can be sure we can facilitate any design feature you may need.



Drop Sides



Steer Axle - available on twin axle and tri-axle trailers



Electric Roll-Over Covers



Bespoke paint and decals to match your outfit



Meshed or Sloped Extension



Optional Catching Board



Grain, Silage & Root Crop Trailers



STANDARD

- Choice of colour: Red, Green, Blue or Black
- Mudguards
- Side Markings
- LED road lights
- Side Lights
- Twin rear lights (each side)
- Axle—127mm Round—12 Tonne @ 105 km/hr
- Brakes—420 x 180 Brake Shoe
- Single Leaf Spring

OPTIONAL EXTRAS

- Self Locking Hydraulic Rear Door
- Roll over cover
- Toolbox
- Catwalk
- Reversing Lights
- Grain Chute
- Catching Board
- Flashing Beacon
- Swivel/Spoon Hitch
- Air Brakes/Suspension
- ABS Brakes

Capacity/Length	16ft	18ft	20ft	22ft	24ft
Outside Width	8ft 3"	8ft 3"	8ft 3"	8ft 3"	8ft 3"
Commercial Axles 127mm round	Twin	Twin	Twin	Twin	Tri/Steering
Suspension	Spring	Spring	Spring	Spring	Spring
Floor	5mm	5mm	5mm	5mm	5mm
Sides	3mm	3mm	3mm	3mm	3mm
Side Height	4ft to 6ft	4ft to 6ft	4ft to 6ft	4ft to 6ft	4ft to 6ft
Brakes	Air/Hydraulic	Air/Hydraulic	Air/Hydraulic	Air/Hydraulic	Air/Hydraulic
Tyres (Standard UK)	385/65/22.5 (new)	385/65/22.5 (new)	385/65/22.5 (new)	445/65/22.5 (new)	445/65/22.5 (new)
Tyres (Standard Ireland)	385/65/22.5 (new)	445/65/22.5 (new)	445/65/22.5 (new)	445/65/22.5 (new)	445/65/22.5 (new)
Drawbar	Sprung	Sprung	Sprung	Sprung	Sprung
Capacity (5ft Sides)	12 Ton	14 Ton	16 Ton	18/20 Ton	22 Ton
Cubic metres (5ft Sides)	18.72	20.38	22.65	24.92	27.18





Livestock Trailers

Livestock Trailers are built in all sizes ranging from 16ft to 32ft. They come standard with aluminium sides, chequered floor and ramp, LED lights, ladder and catwalk, aluminium loading gates, interior loading lights and sprung drawbar. A galvanised slurry tank, galvanised dividing gate, side markings and crash bars are also standard with a large range of optional extras.



Galvanised Dividing Gates



Aluminium Chequered Floor



Galvanised Slurry Tank



Aluminium Loading Gates



Livestock Trailers



STANDARD

- Choice of colour: Red, Green, Blue or Black
- Mudguards
- Side Markings
- LED road lights
- Side Lights
- Twin rear lights (each side)
- Galvanised Dividing Gate
- Galvanised Slurry Tank
- Aluminium Loading Gates

OPTIONAL EXTRAS

- Air Brakes
- ABS Brakes
- Air Suspension
- Tool Box
- Steering Axle - 10 Stud Commercial
- Spoon Hitch
- Reversing Lights
- Extra Dividing Gates
- Lifting Deck
- Ladder & Catwalk

Length	18ft	20ft	22ft	24ft	26ft	28ft	30ft	32ft
Width	8ft	8ft	8ft	8ft	8ft	8ft	8ft	8ft
Height	6ft 5"	6ft 5"	6ft 5"	6ft 5"	6ft 5"	6ft 5"	6ft 5"	6ft 5"
Axles	Single	Single	Single/Twin	Twin	Twin	Twin	Twin	Tri
Suspension	Solid	Solid	Solid/	Spring	Spring	Spring	Spring	Spring
Floor	5mm	5mm	5mm	5mm	5mm	5mm	5mm	5mm
Sides	4mm	4mm	4mm	4mm	4mm	4mm	4mm	4mm
Brakes	Hydraulic	Hydraulic	Hydraulic	Hydraulic	Hydraulic	Hydraulic	Hydraulic	Hydraulic
Tyres	245/70/19.5 (new)	245/70/19.5 (new)	445/45/19.5 (new)	445/45/19.5 (new)	445/45/19.5 (new)	445/45/19.5 (new)	445/45/19.5 (new)	445/45/19.5 (new)
Drawbar	Sprung	Sprung	Sprung	Sprung	Sprung	Sprung	Sprung	Sprung





Bro
ENGINEERING



Broughan

LTD.COM





Bale & Flat Trailers

The Broughan Bale and Flat Trailer ranges from 24ft to 36ft and can be manufactured to heavy duty specification. These trailers are fitted with a choice of tyres, racks and optional extras to suit the customer's specification.

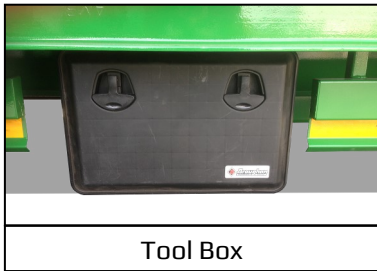

Tool Box



Optional Hydraulic Sidewalk



Optional Hydraulic Box Pusher



Optional Cover

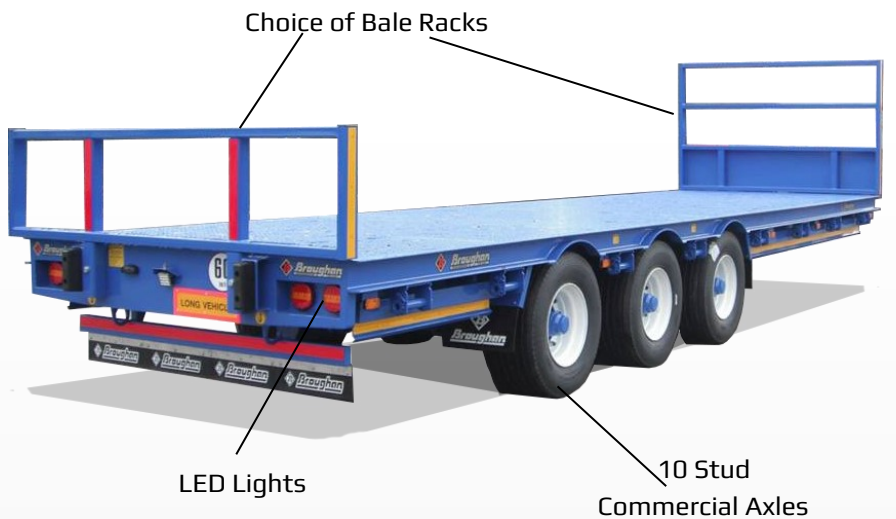
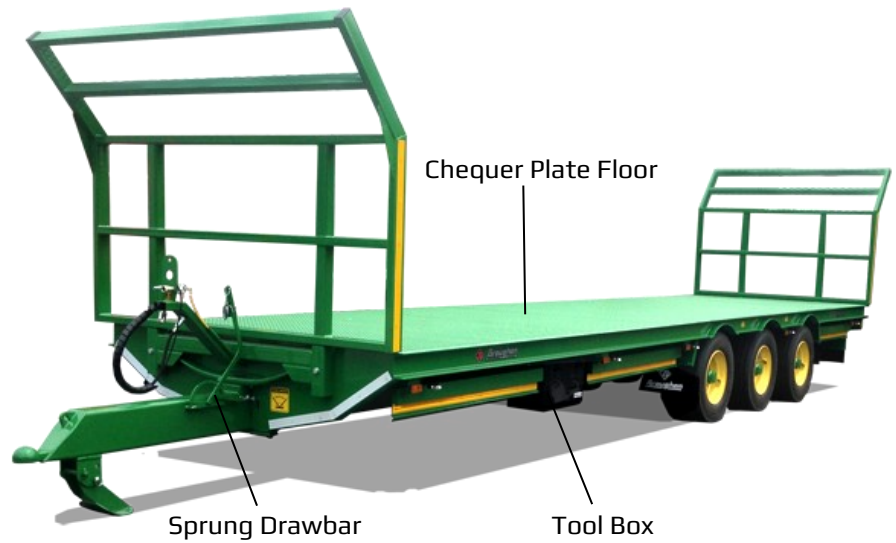

Bale & Flat Trailers



STANDARD

- Choice of colour: Red, Green, Blue or Black
- Mudguards
- Side Markings
- LED Road Lights
- Side Lights
- Twin Rear Lights (each side)
- Tool Box
- Rope Hooks
- Front and Rear Bale Racks



HEAVY DUTY STANDARD

- 4.5mm Steel Chequer Plate Floor
- 10 Stud Commercial Axles (127mm)
- 420 x 180 Brake Shoe
- Front and Rear Bale Racks
- Hydraulic Brakes
- Sprung Drawbar
- Tool Box

OPTIONAL EXTRAS

- Air Brakes
- ABS Brakes
- Swivel Hitch
- Spoon Hitch
- Box Pusher
- Hydraulic Side Catwalks
- Beacons



Length	24ft	27ft	30ft	30ft	32ft	32ft	36ft
Width	8ft 3"	8ft 3"	8ft 3"	8ft 3"	8ft 3"	8ft 3"	8ft 3"
Height	445/45/19.5 = 42" to Floor Level / 560/45/22.5 = 46.5" to Floor Level						
Axles	Twin	Twin	Twin	Tri	Twin	Tri	Tri
Suspension	Spring	Spring	Spring	Spring	Spring	Spring	Spring
Floor	4.5mm Chequer	4.5mm Chequer	4.5mm Chequer	4.5mm Chequer	4.5mm Chequer	4.5mm Chequer	4.5mm Chequer
Brakes	Hydraulic	Hydraulic	Hydraulic	Hydraulic	Hydraulic	Hydraulic	Hydraulic
Tyres	445/45/19.5 (new heavy duty)	445/45/19.5 (new heavy duty)	445/45/19.5 (new heavy duty)	445/45/19.5 (new heavy duty)	445/45/19.5 (new heavy duty)	445/45/19.5 (new heavy duty)	445/45/19.5 (new heavy duty)
Drawbar	Sprung	Sprung	Sprung	Sprung	Sprung	Sprung	Sprung
Capacity	14 Ton	14 Ton	16 Ton	24 Ton	20 Ton	24 Ton	24 Ton





Dumper Trailers

The Broughan Dump Trailer ranges from 12 Ton to 24 Ton Tri Axle. Dump Trailers come standard with 6mm sides, 10mm floor and fold-down or up and over door. Optional extras include a Hardox body, heavier sides or floor with a wide range of tyre options.



Fold Down Door



Optional Steer Axle



Large Range of Tyre Options



Hardox Body Option

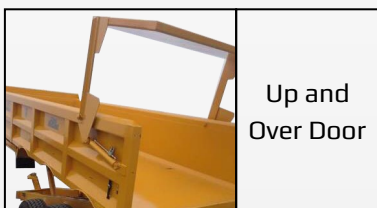

Up and Over Door

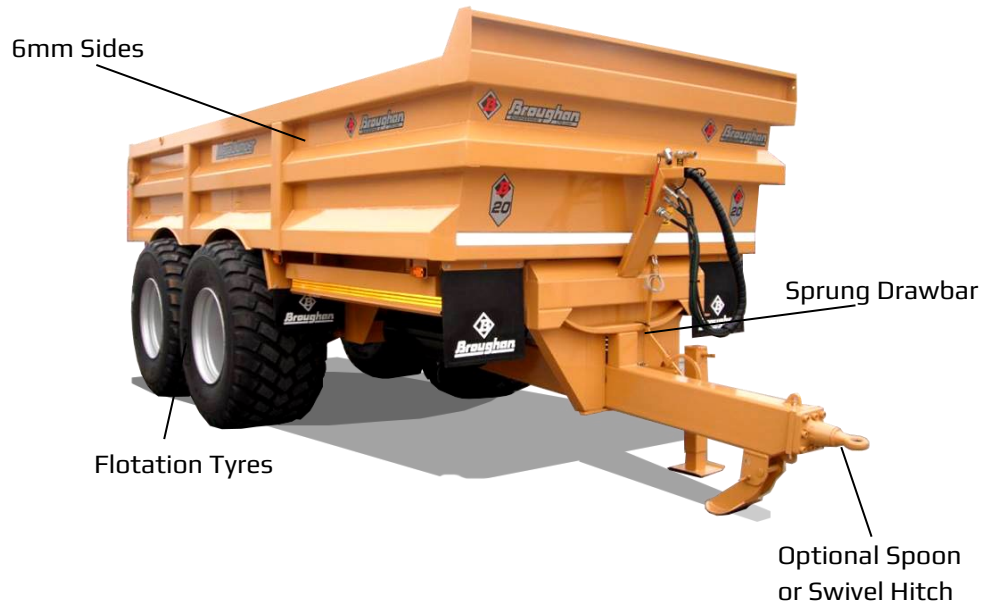

Optional Hardox Body

Fold Down Door



Optional Steer Axle



Up and Over Door



Dumper Trailers



High Tipping Angle



10mm Floor



Cleanable with 6ft Bucket



Optional Spoon or Swivel Hitch

STANDARD

- Choice of colour: Red, Green, Blue or Black
- 10mm Floor, 6mm Sides
- 10 Stud Commercial Axles
- Commercial spring suspension or Bogey
- Auto Tilt tail-door
- Mud Flaps
- Rear and Side Lights
- Sprung Drawbar
- Can be cleaned out with 6ft bucket

OPTIONAL EXTRAS

- Heavier Sides and Floor
- Hardox Material
- Swivel or Spoon Hitch
- Tool Box
- Up and Over Door
- Steer Axle

Capacity	14 Ton	16 Ton	18 Ton	20 Ton	24 Ton
Axles	Twin	Twin	Twin	Twin	Tri
Suspension	Spring	Spring	Spring	Spring	Spring
Floor	10mm	10mm	10mm	10mm	10mm
Sides	6mm	6mm	6mm	6mm	6mm
Brakes	Hydraulic	Hydraulic	Hydraulic	Hydraulic	Air
Tyres	385/65/22.5 (new)	445/65/22.5 (new)	445/65/22.5 (new)	445/65/22.5 (new)	445/65/22.5 (new)
Drawbar	Sprung	Sprung	Sprung	Sprung	Sprung





Low Loaders

Low Loaders are available from 16 Ton to 30 Ton and can be manufactured to a broad range of specifications. A standard Low Loader comes with a hardwood floor, hydraulic ramps, sprung drawbar and commercial axles.



Outriggers



Cheese Wedge Ramps



Twin Axle Low Loader



Hydraulic Ramps



Timber and Strap Box

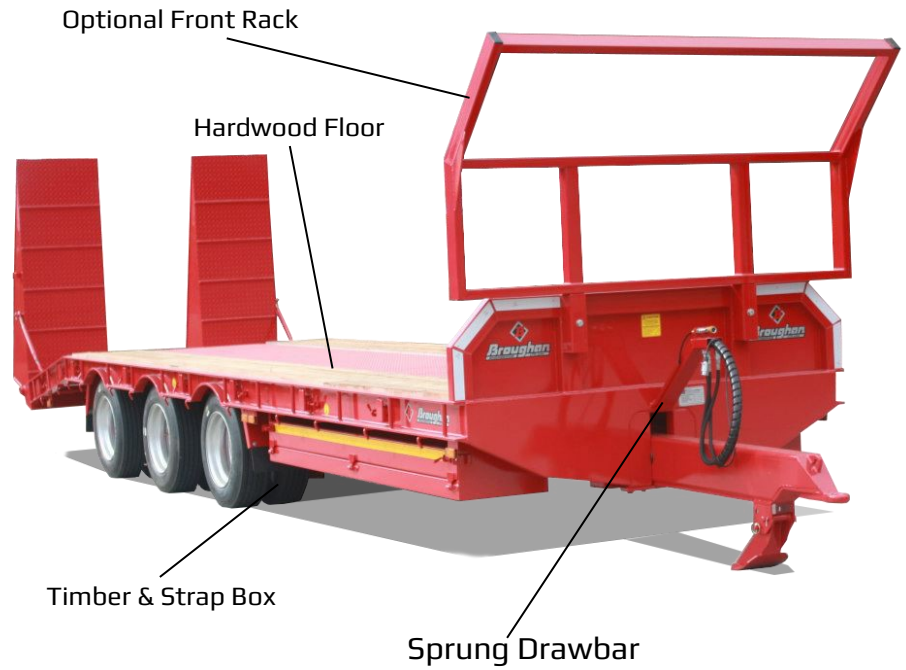

Optional Front Rack

Hardwood Floor

Timber & Strap Box

Sprung Drawbar



Commercial Axles



Low Loaders

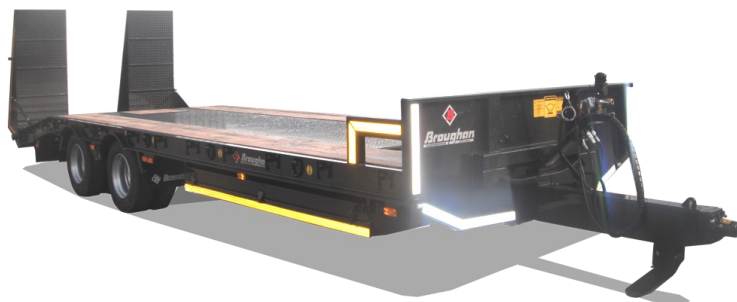

STANDARD

- Choice of colour: Red, Green, Blue or Black
- 10 Stud Commercial Axles
- Hardwood Floor
- Sprung Drawbar
- Mud Flaps
- Rear and Side Lights
- Rear Reflectors
- Hydraulic Ramps

OPTIONAL EXTRAS

- Cheese Wedge Ramps
- Outriggers
- Steer Axle
- Tool Box
- Steer Axle
- Air Brakes
- ABS Brakes
- Flashing Beacon

Capacity	16 Ton	24 Ton	30 Ton
Floor Length	18ft	23ft	23ft
Beaver Length	5ft	5ft	5ft
Outside Width	8ft 3"	8ft 3"	8ft 3"
Height to Floor	36"	36"	36"
Commercial Axles 127mm round	Twin	Tri	Tri
Floor - Either Side	40mm Hardwood Floor	40mm Hardwood Floor	40mm Hardwood Floor
Floor - Down Middle	6mm Chequer Plate	6mm Chequer Plate	6mm Chequer Plate
Floor - Beaver	6mm Chequer Plate	6mm Chequer Plate	6mm Chequer Plate
Sides	8" x 3" Channel	8" x 3" Channel	8" x 3" Channel
Brakes	Hydraulic	Hydraulic	Hydraulic
Suspension	Spring	Spring	Spring
Drawbar	Sprung	Sprung	Sprung
Tyres	245/70/17.5	245/70/17.5	245/70/17.5





Bespoke Trailer Manufacturing

With years of experience in trailer manufacturing, Broughan Engineering can design and build a trailer to suit your needs, whatever the idea or specification.

- Extra Axles
- Drop Sides
- Air Suspension
- Upgrading Your Trailer
- Refurbishing Your Trailer

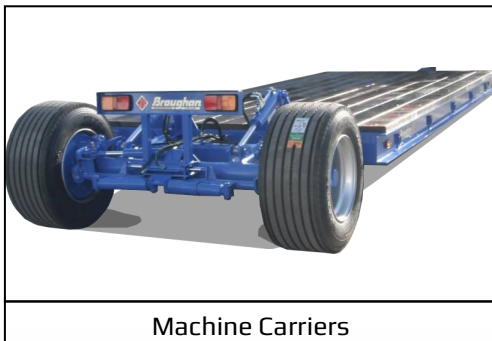
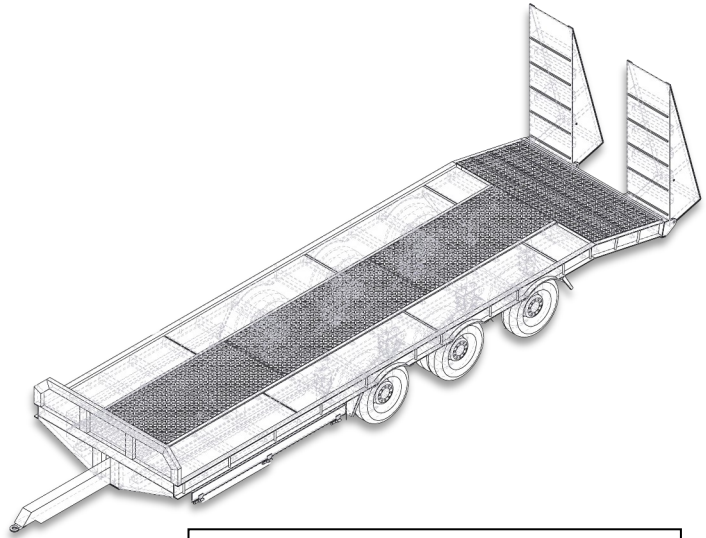

Machine Carriers



Timber Trailers & Fitted Cranes



Hook Lifts



Tipping Trailers



Log Bunks



Smaller Grain Trailers



Wheels & Tyres



We offer a wide range of tyres from various manufacturers to suit your load and capability.

- 445/45R19.5 NEW
- 445/65R22.5 New Tyre—road pattern 18R New
- 550/45R22.5 BKT SL648 20 ply TL 166A8 NEW
- 560/45R22.5 BKT Flotation Ridemax NEW
- 560/55R22.5 BKT Flotation Ridemax NEW
- 560/60R22.5 BKT Flotation Ridemax NEW
- 580/65R22.5 BKT Flotation Ridemax NEW
- 710/50R26.5 BKT Flotation Ridemax NEW

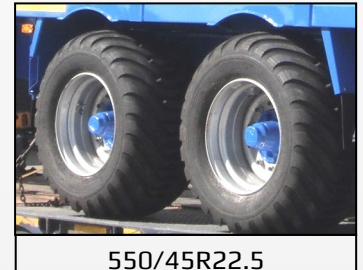
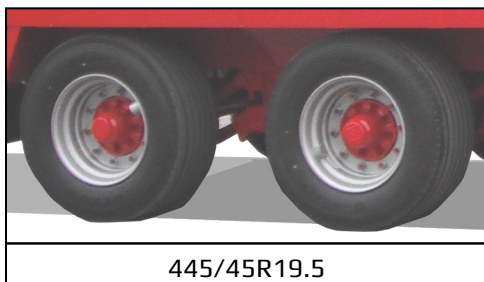



“There was a gap in the market for high quality agricultural trailers and I knew exactly which company I wanted to work with. They ensure the highest quality of material and workmanship”

- George Hill, GRT Machinery, UK



“After looking at most trailers on the market, Broughan’s build quality came out on top. We were quite particular when it came to the colour and lighting and Broughan were willing to listen, and delivered exactly what we wanted. We look forward to doing business with Broughan Engineering again in the near future.”

- Adam Pollock, William Pollock & Son

Dealer Contact Details:



Coppenagh, Tullow, Co. Carlow

Tel: 00 353 (0)59 9163697

Web: broughanengineeringltd.com

Email: info@broughanengineeringltd.com

